

GENERAL CATALOGUE

DELPHI SERIES ASYNCHRONOUS THREE-PHASE ELECTRIC MOTORS

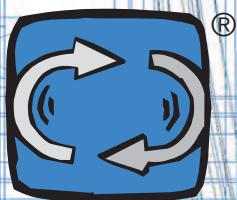

motive

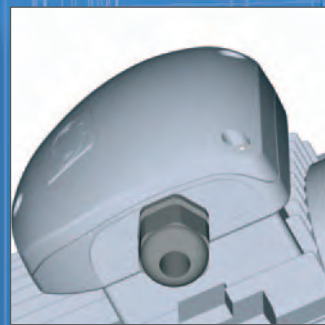
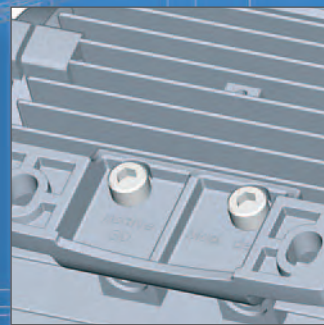
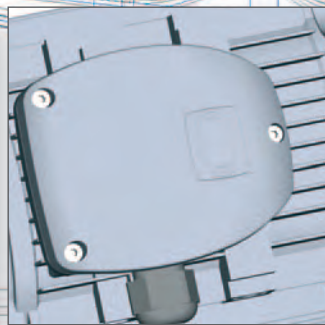
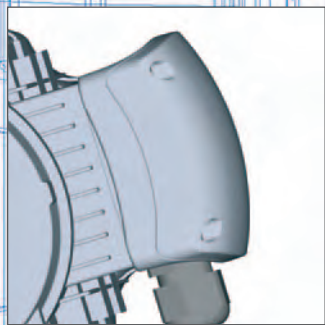



ZERTIFIKAT ♦ CERTIFICATE ♦ СВИДЕТЕЛЬСТВО ♦ CERTIFICADO ♦ CERTIFICAT ♦ CERTIFICATO

CERTIFICATE



Certificato Nr. 30 100 1190 - Rev. 02
Et attesté n° / This is to certify that
**IL SISTEMA QUALITÀ DI
THE QUALITY SYSTEM OF**

MOTIVE SRL



**VIALE VENEZIA 136
I-25123 BRESCIA (BS)**

È CONFORME AI REQUISITI DELLA NORMA
HAS BEEN FOUND TO CONFORM TO THE REQUIREMENTS OF
UNI EN ISO 9001:2000

Questo certificato è valido per il seguente campo di applicazione
This certificate is valid for the following product or service range

**Progettazione, gestione produzione e assistenza di motori
elettrici, riduttori meccanici ed accessori per la trasmissione
di potenza (SA 19, 10)**
**Design, manufacture management and service of electrical
motors, mechanical reducers and accessories for power
transmission (SA 19, 10)**

Totale di validità/certify date
2007-05-19

Decorato
2004-05-31
Local Authority: Commissione Anonima



Per l'Engagement di Certificazione
Per the Certification Body
TUV Italia S.r.l.
C.so della Spadana 410

Nico Mastromaria
Nico Mastromaria
Management Representative



Rinnovo del certificato emesso per la prima volta in data 2001-07-20

Technical characteristics pag. 4-5



Efficiency pag. 6

CE Marking pag. 7

Delphi EX



Protection Type pag. 8

Duty Service pag. 9

Working conditions

Assisted power cooling

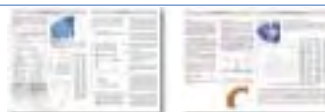

Motive motors protection pag. 10

Three-phase self-braking motors series atdc delphi pag. 11

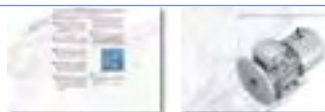

Delphi ATDC pag. 12

Brake description pag. 13

Brake operation

Adjustment



Wiring diagrams pag. 14

Motor configurations and installation positions pag. 15



Table of dimensions pag. 16-17



Technical data pag. 18-19



Technical data pag. 20-21

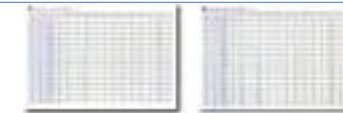

Technical data pag. 22-23



Component list pag. 24

Rubber seal rings and bearings pag. 25



Terms of sale and guarantee pag. 26



TECHNICAL CHARACTERISTICS

Motive motors are built according to international standard regulations; each size throughout the construction forms is calculated with reference to the tables of standard IEC 72-1.

The shapes built per IEC 34-7, are B3, B5, B14, B35.

Motive asynchronous three-phase Delphi series motors are closed, and externally ventilated.

The frame, up to 132 included, is made in die casting aluminium alloy, from size 160 up to 355 the frame is made in cast iron.

All motors are
multiple voltage
multi-frequency 50/60Hz,
F class insulation,
S1 continuous duty service,
IP55 protection
1 or 2 efficiency class
tropicalized.

EFF 1

EFF 2



PATENTED

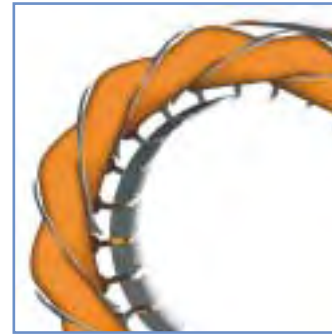

The copper is impregnated with a double layer of H class insulating enamel to ensure high resistance to electrical, thermal and mechanical stress.

The phases are further isolated by another layer of Nomex film to protect the motors from the voltage peaks that usually occur when the motor is controlled by an inverter.



motive motors adopt only bearings selected for their silence and reliability and, for the same objectives, the cage rotor is dynamically balanced according to IEC 34-14 and ISO 9921 norms



Blocking the bearings into their slots with snap rings prevents them from moving axially. From type 90, a steel insert is provided in the bearing slot of the aluminum flanges, to resist to radial mechanical forces with a fair degree of security

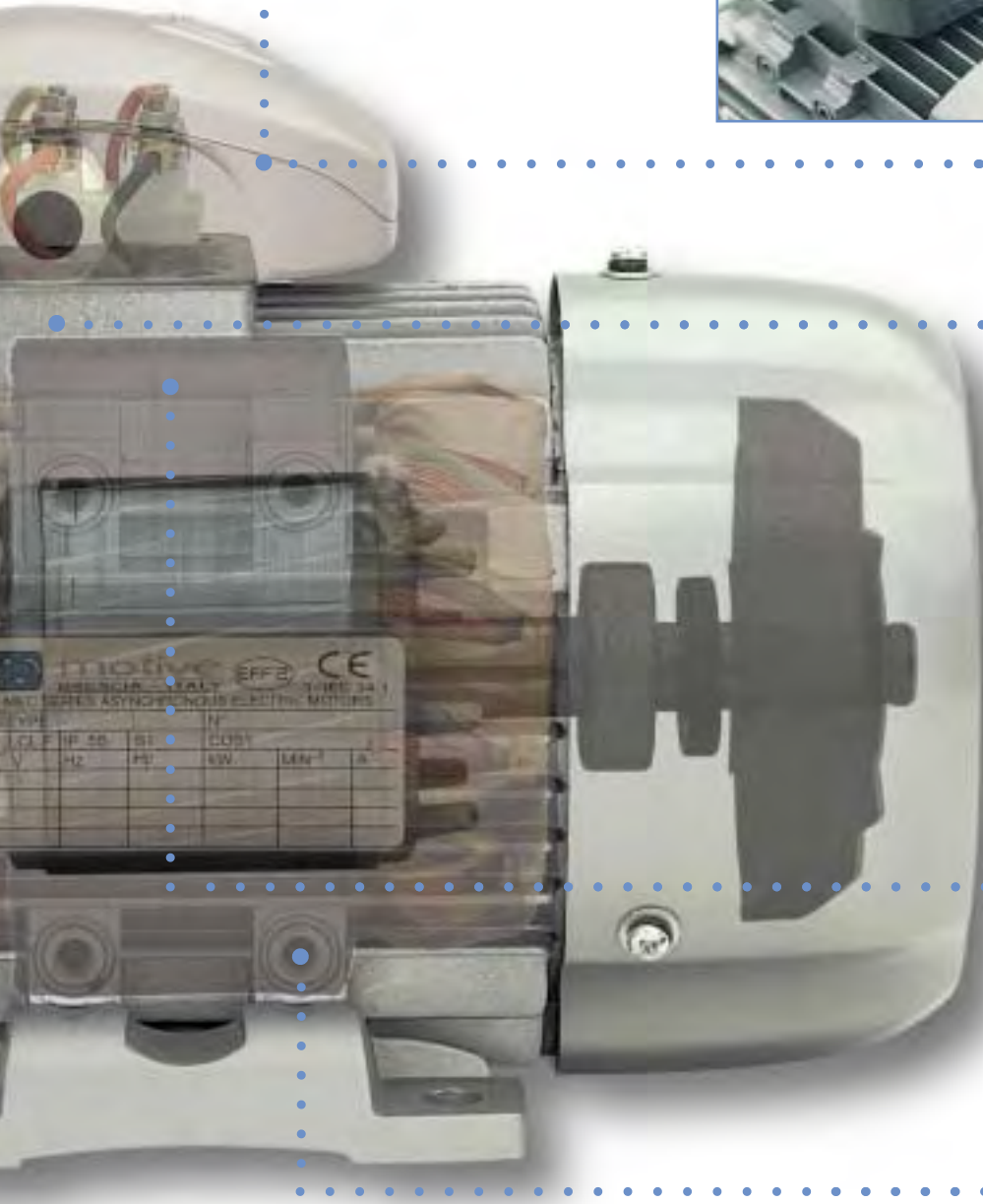

Aiming the maximum protection, the motors are equipped with important details like the pull-resistant cable press and the combination of bearings with two shields each with rubber seal rings



Cable press can be easily moved on both the sides of the connection box, thanks to the screw cap



the connection box can be rotated of 360° with steps of 90°



To protect them by the rust, motive motors are painted in silver RAL9006 colour

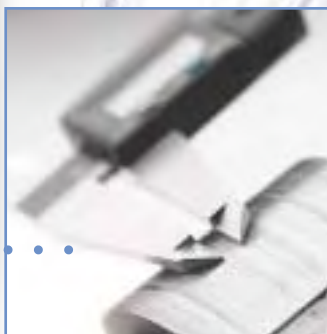

Performance excellence is granted by the FeV magnetic lamination sheets adoption, instead then the usual normal FePO1, FeV lamination sheets provide higher efficiency, lower heating, energy saving and longer life to isolation materials

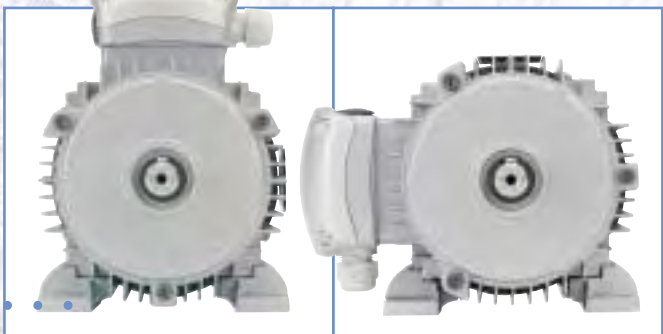

Feet and connection box can be moved to the right or left

EFFICIENCY

The European Agreement issued by the European Commission and CEMEP (European Committee of Manufacturers of Electrical Machines and Power Electronics), establishes a new classification system of electric motors based on the efficiency. The reference values are shown by the attached diagram and the following paragraph.

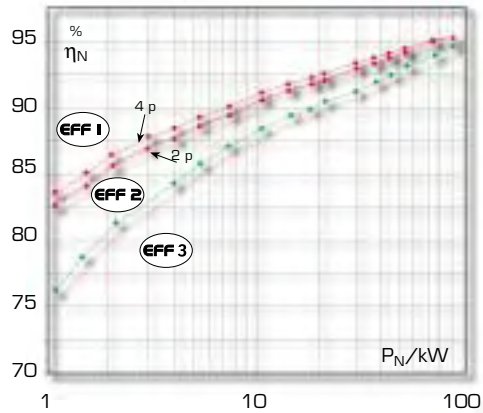

There are no requests about minimum efficiency, but it is defined clearly which are the motors classified efficiency 1, 2 and 3.

Motive has organized its production respecting the parameters indicated by the new European classification.

Client's benefits are of many kinds

BILL EFFECTS

Bill effects are the first to be in evidence. The calculation changes depending by the use circumstances, but we can say that efficiency 2 motors allow a saving of about 20%. For instance, a 15kW motor, for an operation period of 6.000 hours per year, can save about 2 MWh/a or more: about 100 Euro of yearly operation costs

DURABILITY EFFECTS

Higher efficiency motors heat less, slowing down the aging cycle of the insulating materials and living longer. Average operating life of Eff.2 Motive motors is:

2500 hours/ year for motors up to 15kW
4000 hours/year for bigger motors
The average life is approximately from 25 to 30.000 hours for the first and 50,000 for the second ones

AMBIENT EFFECTS

Efficiency 2 motors guarantee great energy and money savings, with an objective of sustainable development, reduction of CO₂ emissions and consequent improvement of the quality of the atmosphere

HOW TO MAKE A MORE EFFICIENT MOTOR?

High efficiency can be seen in many ways: like the relation between output power and input absorbed power, or like a measure of the losses that born when converting the electric power in mechanical energy.

From another perspective, high efficiency motors consume less energy to produce the same torque

on the shaft. Basically, an high efficiency motor is the result of precise workings, lower frictions, a dynamically balanced rotor, smaller space between rotor and stator and of the use of better materials. The main factors for the design are based on the choice of the type of lamination sheets and windings with a greater coil number and a bigger diameter wire..

Among all materials that compose a motor, laminations have the highest influence on performance

SILICON MAGNETIC LAMINATIONS

Motive motors are made with FeV magnetic lamination sheets, rather than the customary normal Fe PO1 iron lamination sheets.

Further than raw material, the sheets thickness is another performance source. In fact, the thinner is the sheet, the higher are the performances.

The lamination sheets Fe PO1 can reach up to 1mm thickness.

FeV magnetic lamination sheets have a 0,5mm maximum thickness.

Composition and thickness give to magnetic lamination sheets a very low W/Kg loosing factor:

Lower specific losses mean less magnetising current for the same Power and torque (thus less heating).

EURO NORM	W/ Kg a 1T	W/ Kg a 1,5T
106-84	1,70	4,00

data at 400V 50Hz

Instead, no standard prescribes a maximum loosing factor for Fe PO1 lamination sheets; although we can say that generally this is at least the double of FeV lamination sheets,

not even this data can be guaranteed. This is a source of potential performance diversities between motor and motor.

The reason of a longer life is based on the lower heating that lengthens the ageing cycle of the insulation materials.

Between all the raw materials that compose an asynchronous electric motor, lamination sheets iron is the main performance discriminating factor.







The main advantages given by the adoption of silicon magnetic laminations are:

- higher efficiency
- better guarantees on the quality constancy, assured by tolerances reported in international norms





Motors 2 poles			
kW	efficiency		
	eff3	eff2	eff1
1.1	<76.2	≥76.2	>82.8
1.5	<78.5	≥78.5	>84.1
2.2	<81.0	≥81.0	>85.6
3	<82.6	≥82.6	>86.7
4	<84.2	≥84.2	>87.6
5.5	<85.7	≥85.7	>88.6
7.5	<87.0	≥87.0	>89.5
11	<88.4	≥88.4	>90.5
15	<89.4	≥89.4	>91.3
18.5	<90.0	≥90.0	>91.8
22	<90.5	≥90.5	>92.2
30	<91.4	≥91.4	>92.9
37	<92.0	≥92.0	>93.3
45	<92.5	≥92.5	>93.7
55	<93.0	≥93.0	>94.0
75	<93.6	≥93.6	>94.6
90	<93.9	≥93.9	>95.0

Motors 2 poles			
kW	efficiency		
	eff3	eff2	eff1
1.1	<76.2	≥76.2	>83.8
1.5	<78.5	≥78.5	>85.0
2.2	<81.0	≥81.0	>86.4
3	<82.6	≥82.6	>87.4
4	<84.2	≥84.2	>88.3
5.5	<85.7	≥85.7	>89.2
7.5	<87.0	≥87.0	>90.1
11	<88.4	≥88.4	>91.0
15	<89.4	≥89.4	>91.8
18.5	<90.0	≥90.0	>92.2
22	<90.5	≥90.5	>92.6
30	<91.4	≥91.4	>93.2
37	<92.0	≥92.0	>93.6
45	<92.5	≥92.5	>93.9
55	<93.0	≥93.0	>94.2
75	<93.6	≥93.6	>94.7
90	<93.9	≥93.9	>95.0

CE marking is referred to:

-  Community Low Voltage Directive (LVD) 73/23 EEC, modified by the Community Directive regarding marking 93/68 EEC
-  Community Electromagnetic Compatibility Directive (EMC) 89/336 EEC and its modifications 91/263 EEC, 92/31 EEC e 93/68 EEC
-  Community Machinery Directive (MD) 89/392 EEC and its modifications 91/368 EEC, 93/44 EEC e 93/68 EEC
-  EN 50082-1 (last issue). Electromagnetic compatibility - Generic immunity standard - Part 1: residential and light industry environment
-  EN 50081-2 (last issue). Electromagnetic compatibility - Generic emission standard - Part 2: Industrial environment
-  EN 50082-2 (last issue). Electromagnetic compatibility - Generic immunity standard - Part 2: Industrial environment





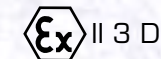
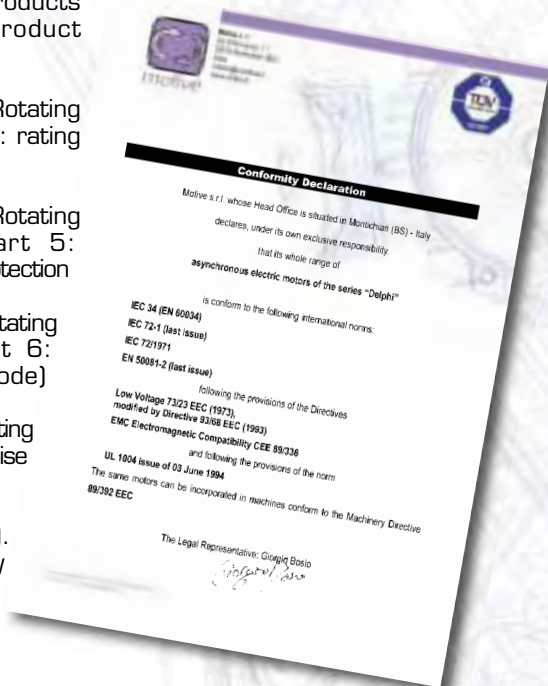

CE marking is put by Motive as a visible sign of the product compliance with the requirements of above mentioned directives. In order to reach this conformity, Motive products respect the following product standards:

-  EN 60034-1 (last issue). Rotating electrical machines. Part 1: rating and performance
-  EN 60034-5 (last issue). Rotating electrical machines. Part 5: classification of degrees of protection
-  EN 60034-6 (last issue). Rotating electrical machines. Part 6: methods of cooling (IC code)
-  EN 60034-9 (last issue). Rotating electrical machines. Part 9: noise limits
-  EN 50081-1 (last issue). Electromagnetic compatibility - Generic emission standard - Part 1: residential and light industry environment



In order to meet the safety concerns in dust-filled atmospheres, the Delphi series motors are also available, upon request, in the version Delphi Ex. Conforming to the Essential safety requirement of the ATEX 94/9/EC European Directive (ATEX 95), these motors have been designed to operate in the zone 22 (Group II Category 3 D Tmax surf. 125°C).

Their "Ex" marking refers to the following norms:

-  CEI EN 50281-1-1 1999-11
-  CEI EN 50281-1-1/A1 2002-10
- Electrical apparatus for use in the presence of combustible dust Part 1-1: Electrical apparatus protected by enclosures – Construction and testing
-  CEI EN 50281-2-1 1999-11
- Electrical apparatus for use in the presence of combustible dust. Part 2-1: Test methods – Methods for determining the minimum ignition temperatures of dust
-  CEI EN 50281-1-2 1999-09
- Electrical apparatus for use in the presence of combustible dust Part 1-2: Electrical apparatus protected by enclosures Selection, installation and maintenance
-  CEI EN 50014 1998-06
-  CEI EN 50014/A1/A2 1999-08
- Electrical apparatus for potentially explosive atmospheres. General requirements

PROTECTION TYPE

The protection against people accidental contacts and/or the entry of corps and/or the entry of water is expressed at international level (EN60529) by a symbolic acronym composed by a group of 2 letters and 2 numbers.

IP index of protection reference letters

1° num. Protection of people against contacts and protection against the entry of solid corps

2° num. Protection against harmful entry of water

Motive motors are IP55 protected

1° number	2° number
0	no protection
1	protection against solid corps bigger than 50mm
2	protection against solid corps bigger than 12mm
3	protection against solid corps bigger than a 2,5mm
4	protection against solid corps bigger than 1 mm
5	protection against harmful dust deposits
6*	complete protection against the total penetration of dust*

1° number	2° number
no protection	no protection
protection against vertical water drops	protection against vertical water drops
protection against water drops fall up to 15° of inclination	protection against water drops fall up to 15° of inclination
protection against water drops up to 60° of inclination	protection against water drops up to 60° of inclination
protection against water sprayed by all directions	protection against water sprayed by all directions
protection against water launched by a nozzle of 6,3mm D with a water capacity 12,5lt/min at a distance of maximum 3 mt for 3 min	protection against water launched by a nozzle of 6,3mm D with a water capacity 12,5lt/min at a distance of maximum 3 mt for 3 min
protection against water projections similar to sea waves*	protection against water projections similar to sea waves*

* OPTIONAL



RAIN SHIELD

For outdoor applications with V5 - V18 - V1 - V15 installation, we recommend to mount a rain shield. This configuration may also be used in textiles processing industry.

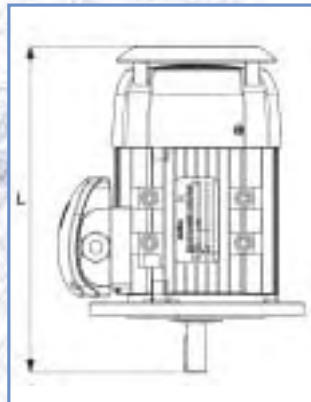

TYPE	L
63	215
71	323
80	369
90S	403
90L	428
100	469
112	453
132S	573
132M	613
160M	770
160L	825
180M	915
180L	955
200L	1025
225S	1155
225M	1160
250M	1220
280S	1265
280M	1315
315S	1540
315M	1570
315L	1680
355M	1840
355L	1870

DUTY SERVICE

All Motive motors shown in this catalogue are made for S1 continuous duty service, as per IEC 34-1 norm. The duty service class is shown on the rating plate. Below are described the various types of service:

S1 - Continuous service:
operating at constant load of duration N in order to reach a thermal balance.

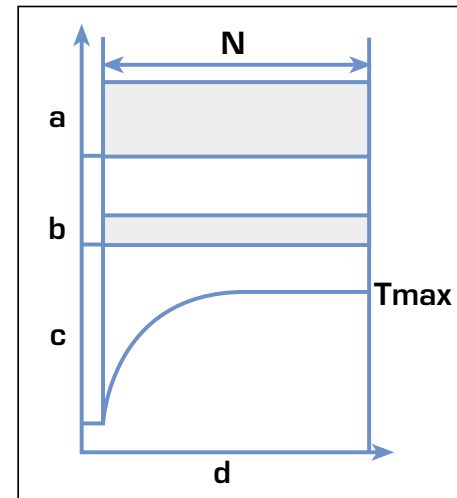

a = load
b = electric losses
c = temperature
d = time
N = steady load operating time
Tmax = max temperature achieved

S2 Limited-duration service: operating at constant load of duration N, less than the time necessary to reach a thermal balance followed by a rest period sufficient in order to restore the balance between the machine temperature and that of the cooling fluid, with a tolerance of 2° C.

S3 Periodic intermittent service: sequence of identical operating cycles, each including a period of operation at constant load N and a rest period R. In this type of service, the cycles is such that start-up does not significantly affect the peak temperature.

S4 - Periodic intermittent service with start-up: sequence of identical operating cycles, each including a substantial start-up stage D, a constant-load operating period N and a rest period R.

S5 - Periodic intermittent service with electric braking: sequence of operating cycles as for S4, with the addition of a rapid electric braking F.

S6 Uninterrupted periodic service with intermittent load: sequence of identical operating cycles, each including a constant load operating period N and a no-load period V. No rest time is included

S7 Uninterrupted periodic service with electric braking: sequence of operating cycles as for S5, but without a rest period

S8 Uninterrupted periodic service with correlated load and velocity variations: sequence of identical operating cycles, each of which includes a constant-load operating period N corresponding to a pre-set rotation speed, followed by one or more operating periods with other constant loads N2, N3, et., corresponding to different rotation speeds. There is no rest period.

S9 Service with non-periodic variations in load and speed: service in which the load and speed generally vary in a non-periodic fashion within the admissible operating field. This service includes frequently applied overloads which may be greatly superior to the full load.

WORKING CONDITIONS

HUMIDITY:

The electrical equipment must be able to work with a relative humidity between 30 and 95% (without condensation). Damaging effects of occasional condensation must be avoided by adequate equipment design or, if necessary, by additional measures (for example, built-in heating or air-conditioning equipment, drainage holes).

ALTITUDE AND TEMPERATURE:

the powers indicated are intended for regular use at altitudes below 1000 mt above sea level and a room temperature between +5°C and +40°C for motors having a rated power below 0.6 kW, or between -15°C and 40°C for motors having a rated power equal to or greater than 0.6 kW (IEC 34-1): For working conditions

rather than those specified (higher altitude and/or temperature) the power decreases of 10% each 10°C of higher temperature, and of 8% for each 1000 mt of higher altitude.

It is not necessary to reduce the rated power if at an altitude higher than 1000mt and lower than 2000mt there is a max ambient temperature of 30°C or, in altitudes from 2000 mt to 3000mt there is a max ambient temperature of 19°C.

VOLTAGE - FREQUENCY:

The maximum variation of the supply voltage is +10%.

Within this tolerance Motive motors supply the rated power.

INSULATION:

The copper is impregnated with a double layer of H class insulating enamel to ensure high resistance to electrical, thermal and mechanical stress.

A NOMEX* /D.M./D.M.D./N.M./N.M.N./M. film that wraps entirely around the coil side insulates the copper and iron from one another.

The phases are further isolated by another layer of NOMEX* /D.M./D.M.D./N.M./N.M.N./M. to protect the motors from voltage peaks that usually occur when the motor is controlled by inverter.

Below is a graph showing the operating temperatures possible for stator windings based on the insulation rating shown on the machine plate

Classe	ΔT (°C)	Tmax (°C)
A	60+5°	105
E	75+5°	120
B	80+5	130
F	105+5°	155
H	125	180

Motive motors are designed to not to pass the max temperatures of their class even under S1 continuous duty service.



ASSISTED POWER COOLING

three-phase 400/50 400/60, IP 55, with separate terminal box



For applications with a power supply below a frequency of 50Hz, the appropriate assisted power cooling must be mounted as there are too many variables involved to determine the various possible thermal duties, and thus the temperatures reached by the motors

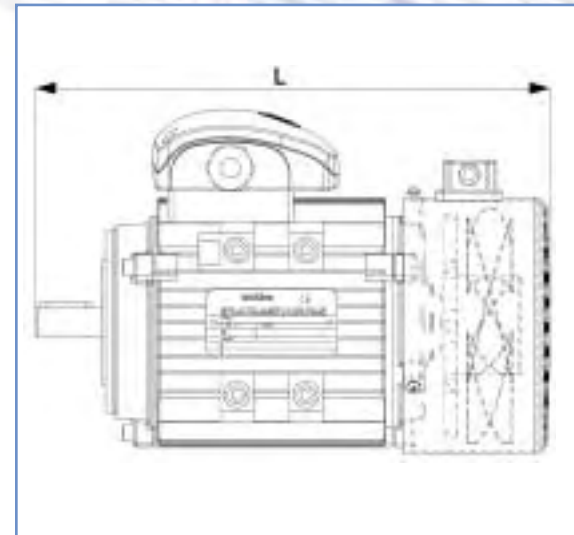

TYPE	POWER W	CAPACITY m³/h	L SIZE
71	30	300	320
80	35	350	366
90S	50	500	400
90L	50	500	425
100	65	650	466
112	65	1000	450
132S	90	880	570
132M	90	880	610
160M	90	1100	710
160L	90	1100	765
180M	100	1200	805
180L	100	1200	845
200L	180	2500	910
225S	200	3800	1035
225M	200	3800	1040
250M	320	4200	1110
280S	370	5000	1160
280M	370	5000	1210
315S	500	6000	1410
315M	500	6000	1440
315L	500	6000	1550
355M	600	6500	1715
355L	600	6500	1745

ENCODER

motors with encoder or special shaft configurations for encoder mounting are available upon request. In this case, assisted power cooling is also available, supported by brackets on the fan cover

protections must be chosen based on the specific running conditions, according to standards EN 60204-1.

- Protection for motors with a shaft power greater than or equal to 0.5 kW with continuous S1 service. This protection may be achieved by means of a thermal cut-out relay, which automatically control a knife switch.
- Protection against peak currents by magnetic relay that controls an automatic knife switch, or by fuses; these must be set to the locked rotor current.
- If the application requires, protection against excessive speed of the electric motor, for example if the mechanical load may drive the electric motor itself and thereby create a hazardous situation.
- If special conditions or synchronised operation with other machines or parts of machines require it, protection against power failures or dips by means of a minimum voltage relay that controls an automatic power knife switch.

The electrical protections on the motor power line may not be sufficient to protect against overloads. If the cooling conditions worsen, the motor overheats but the electrical conditions do not change, which inhibits line protections. Installing built-in protections on the windings solves this problem:

- **PTO** bimetallic device
this is a normally-closed electromechanical device that opens electrically when the threshold temperature is reached; it automatically resets when the temperature falls below the threshold level. Bimetallic devices are available with various intervention temperatures and without automatic reset, per EN 60204-1.
- **PTC** thermistor device
this device promptly, positively adjusts its resistance once the threshold temperature is reached. Motive motors from type 160 to type 355L are equipped with 3 PTC thermistors in the winding, with temperature intervention of 150°C in Class F motors (standard), or 180°C in H Class motors.

- **PT100** device
this is a device that continuously, increasingly adjusts its resistance according to the temperature. It is useful for constant measuring of the winding temperatures using electronic equipment.



THREE-PHASE SELF-BRAKING MOTORS SERIES DELPHI ATDC

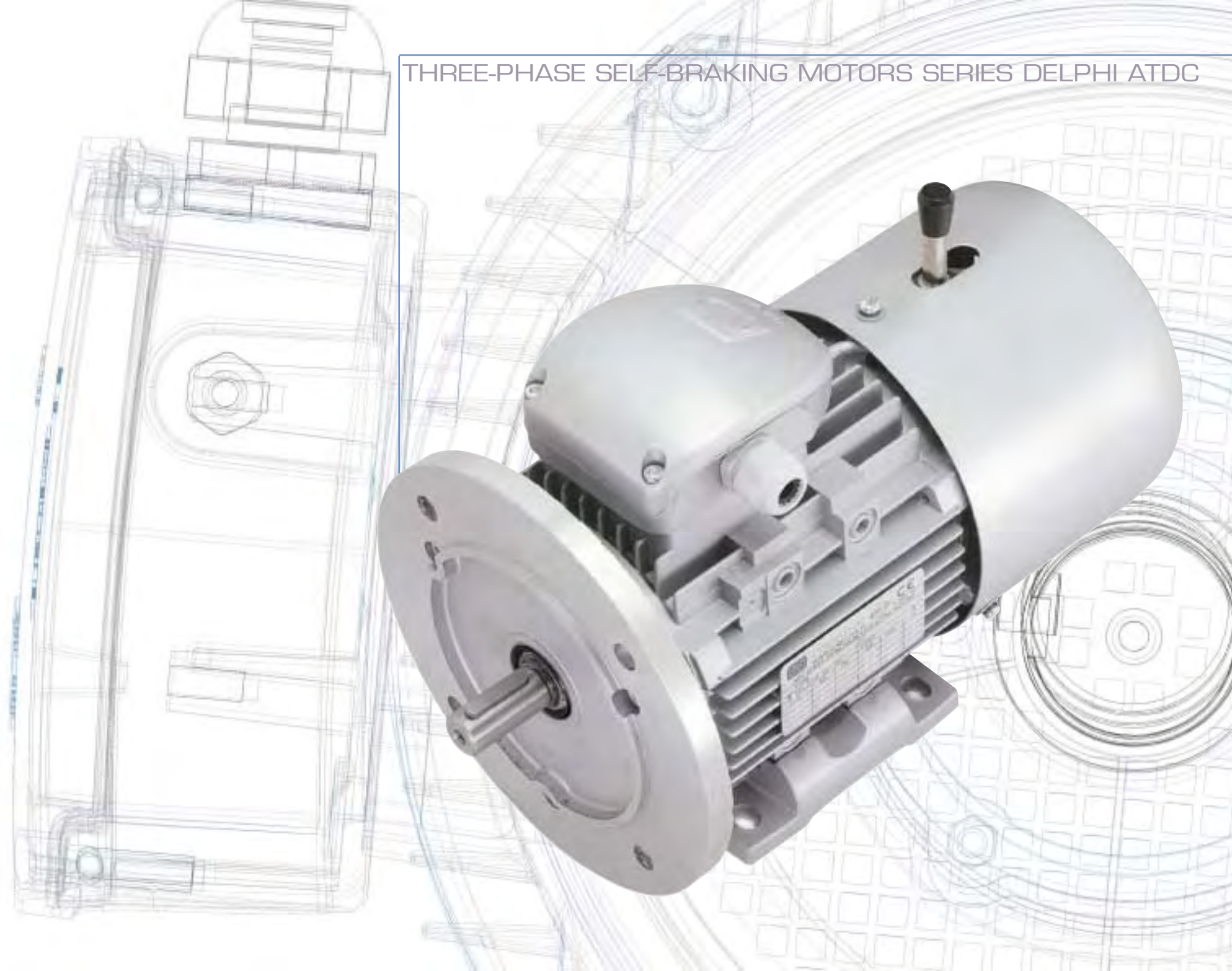

DELPHI ATDC

Delphi ATDC series self-braking motors use spring-pressure brakes, firmly spliced onto a cast iron shield at the back of the motor.

These motors include a series of characteristics normally considered options by other brands, like:

The hand release lever permits to release the brake, making it possible to move the shaft.

The separate brake power supply is achieved, whenever needed, by connecting directly to the brake terminal board located inside the motor terminal box.

The PTO thermal protectors in the winding



TYPE	L
ATDC 63	240
ATDC 71	270
ATDC 80	375
ATDC 90S	400
ATDC 90L	426
ATDC 100L	465
ATDC 112M	495
ATDC 132S	570
ATDC 132M	610
ATDC 160M	715
ATDC 160L	760

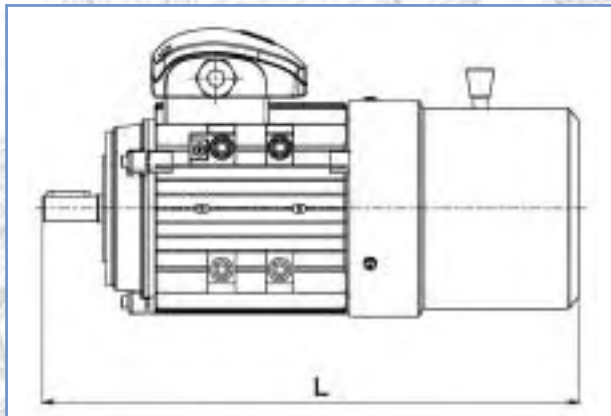

KW	HP	Type	Braking torque full-load Nm	Braking torque no-load sec	Brake input power W	Kg
0,18	0,25	ATDC 63A-2	4,0	0,15	25	7,8
0,25	0,35	ATDC 63B-2	4,0	0,15	25	8,1
0,37	0,5	ATDC 71A-2	4,0	0,15	25	9,0
0,55	0,75	ATDC 71B-2	4,0	0,15	25	9,5
0,75	1	ATDC 80A-2	7,5	0,20	50	12,7
1,1	1,5	ATDC 80B-2	7,5	0,20	50	13,5
1,5	2	ATDC 90S-2	15,0	0,25	60	16,3
2,2	3	ATDC 90L-2	15,0	0,25	60	18,0
3	4	ATDC 100L-2	30,0	0,30	80	27,0
4	5,5	ATDC 112M-2	40,0	0,35	110	37,0
5,5	7,5	ATDC 132SA-2	75,0	0,40	130	49,1
7,5	10	ATDC 132SB-2	75,0	0,40	130	54,5
11	15	ATDC 160MA-2	150,0	0,50	150	84,2
15	20	ATDC 160MB-2	150,0	0,50	150	93,0
18,5	25	ATDC 160L-2	150,0	0,50	150	103,5

0,12	0,18	ATDC 63A-4	4,0	0,15	25	7,8
0,18	0,25	ATDC 63B-4	4,0	0,15	25	8,1
0,25	0,35	ATDC 71A-4	4,0	0,15	25	9,0
0,37	0,5	ATDC 71B-4	4,0	0,15	25	9,5
0,55	0,75	ATDC 80A-4	7,5	0,20	50	13,4
0,75	1	ATDC 80B-4	7,5	0,20	50	14,8
1,1	1,5	ATDC 90S-4	15,0	0,25	60	16,5
1,5	2	ATDC 90L-4	15,0	0,25	60	18,3
2,2	3	ATDC 100LA-4	30,0	0,30	80	26,8
3	4	ATDC 100LB-4	30,0	0,30	80	29,5
4	5,5	ATDC 112M-4	40,0	0,35	110	37,5
5,5	7,5	ATDC 132S-4	75,0	0,40	130	51,5
7,5	10	ATDC 132M-4	75,0	0,40	130	57,5
11	15	ATDC 160M-4	150,0	0,50	150	87,5
15	20	ATDC 160L-4	150,0	0,50	150	100,6

0,37	0,5	ATDC 80A-6	7,5	0,20	50	12,9
0,55	0,75	ATDC 80B-6	7,5	0,20	50	14,4
0,75	1	ATDC 90S-6	15,0	0,25	60	16,6
1,1	1,5	ATDC 90L-6	15,0	0,25	60	18,2
1,5	2	ATDC 100L-6	30,0	0,30	80	29,0
2,2	3	ATDC 112M-6	40,0	0,35	110	36,2
3	4	ATDC 132S-6	75,0	0,40	130	50,2
4	5,5	ATDC 132MA-6	75,0	0,40	130	53,0
5,5	7,5	ATDC 132MB-6	75,0	0,40	150	57,2
7,5	10	ATDC 160M-6	150,0	0,50	150	85,6
11	15	ATDC 160L-6	150,0	0,50	150	90,0

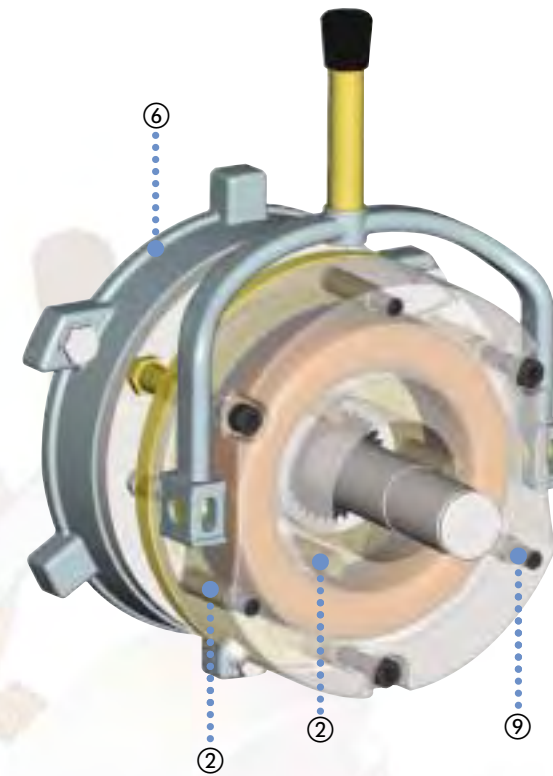
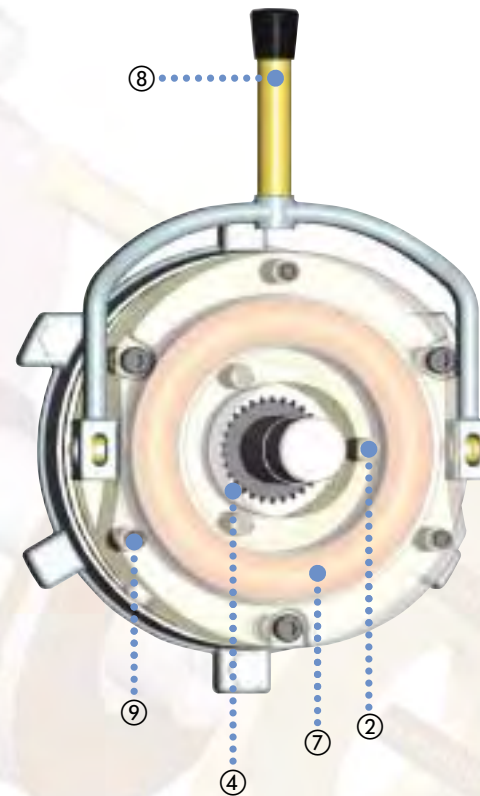
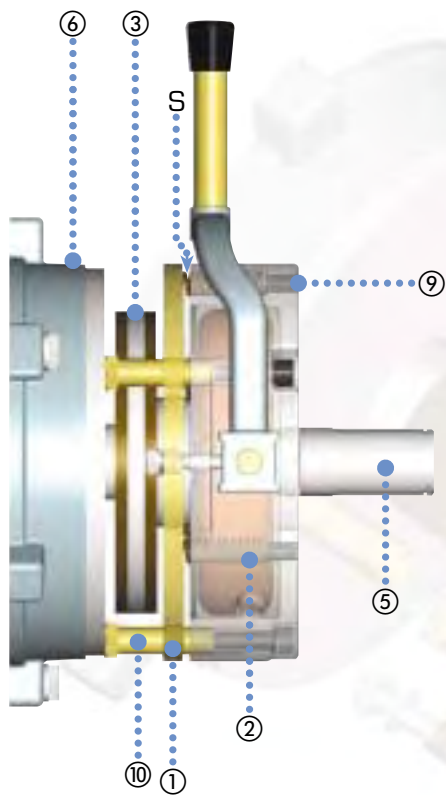

- ① Mobile armature
 - ② springs
 - ③ Brake disc
 - ④ Driver
 - ⑤ Motor shaft
 - ⑥ Motor flange
 - ⑦ Electromagnet
 - ⑧ Release lever
 - ⑨ Adjuster screws
 - ⑩ Threaded bush
- S** Air gap

BRAKE DESCRIPTION

The Delphi ATDC series brake is an electromagnetic brake with negative operation, whose braking action is exercised in the absence of power supply. The brake insulation class is F. The brake lining is asbestos-free, as per most recent EEC Directives in terms of Workplace Hygiene and Safety. All brake assemblies are protected against corrosion by painting and/or heat galvanizing. The parts most subject to wear are treated in special atmospheres that provide considerable wear resistance to the parts. The standard supply voltage of the brake is 230V ±10% 50/60Hz on the AC of the brake power pack

BRAKE OPERATION

When the power supply is interrupted, the excitation coil ⑦ is no longer powered and therefore doesn't exert the magnetic force necessary to restrain the mobile armature ①, which, pushed by the pressure springs ②, compresses the brake disk ③ against the motor flange ⑥ on one side and the armature itself on the other, thereby creating a braking action.

ADJUSTMENT

Two different types of adjustment are possible

S air gap adjustment

For proper operation, the air gap S between electromagnet ⑦ and the mobile armature ① must be between the following indicated limits:

MOTOR TYPE	S AIR GAP (mm)
63-71	0.40-0.50
80-160	0.50-0.60

The adjustment is made by using the threaded bushes ⑩, using a thickness gauge to make sure that the wished air gap is reached.

Braking torque adjustment

The braking torque can be increased by tightening the adjuster screws ⑨. The setting has already been made by motive at the max value, and therefore we suggest to not to intervene on it.

WIRING DIAGRAMS

Motive three phase motors can be connected "Star" or "Delta".

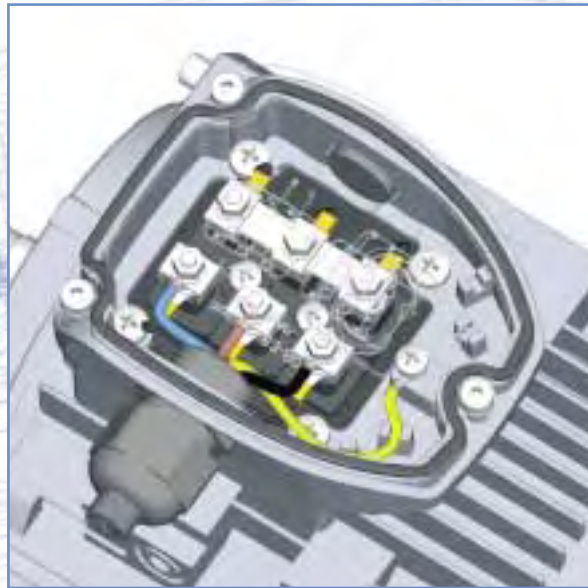

STAR CONNECTION

Star connection is obtained by connecting together the terminals W2, U2, V2 and supplying the terminals U1, V1, W1.

The phase current and voltage are respectively:

$$I_{ph} = I_n$$

$$U_{ph} = U_n / \sqrt{3}$$

where I_n is the supply line current and U_n is the supply line voltage of Star connection

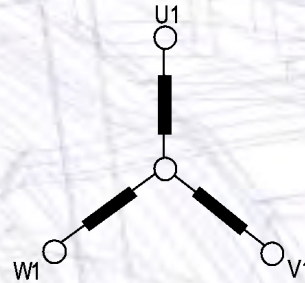

the following voltages and frequencies are inside the standard power supply of all three-phase motive motors, under S1 duty service:

Size	Hz	Volts	
56-132	50	230	400
		220	380
		240	415
	60	260	440
		265	460
		280	480
132-355	50	400	690
		380	660
		415	720
	60	440	760
		460	795
		480	830

DELTA CONNECTION

Delta connection is obtained by connecting the end of a phase with the beginning of the following one. The phase current I_{ph} and the phase voltage U_{ph} are respectively:







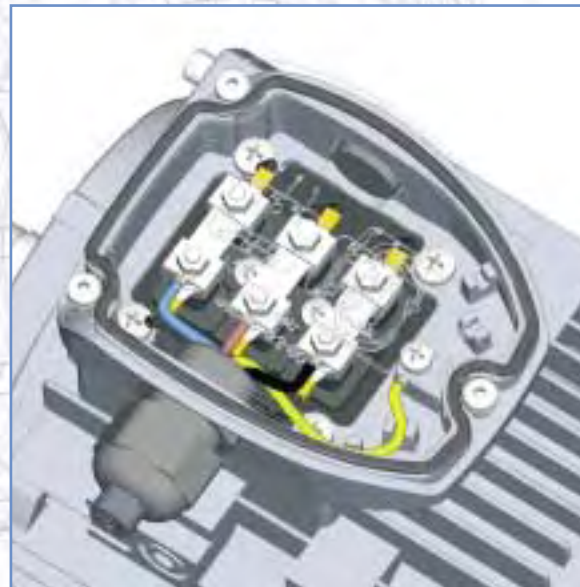
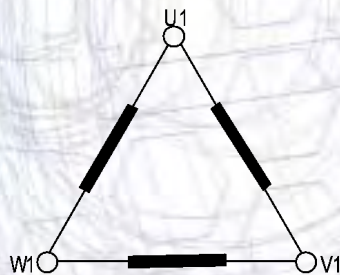

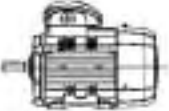
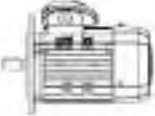

$$I_{ph} = I_n / \sqrt{3}$$

$$U_{ph} = U_n$$

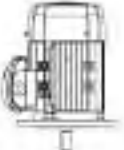
where I_n and U_n are referred to Delta connection.

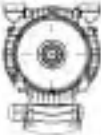
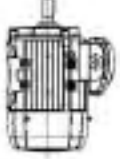

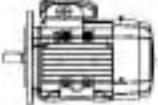
MOTOR CONFIGURATIONS AND INSTALLATION POSITIONS (IEC 34-7)

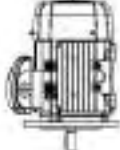
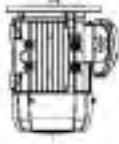
MOTORS WITH FEET B3		FLANGE-MOUNTED MOTORS B5	FLANGE-MOUNTED MOTORS B14
 IM1051 (IM B6)	 IM1001 (IM B3)	 IM3001 (IM B5)	 IM3601 (IM B14)
 IM1061 (IM B7)	 IM1011 (IM V5)	 IM3011 (IM V1)	 IM3611 (IM V18)
 IM1071 (IM B8)	 IM1031 (IM V6)	 IM3031 (IM V3)	 IM3631 (IM V19)
 IM2001 (IM B35)	 IM2101 (IM B34)	 IM2011 (IM V15)	 IM2031 (IM V36)
B3/B5	B3/B14	V1/V5	V3/V6



TYPE	POLES	AC	AD	H	KK	L	D	DH	E	F	G	B3					B5, B3/B5						B14					
												A	AB	B	C	K	M	N	P	R	S	T	M	N	P	R	S	T
56	2-8	120	102	56	M16	164	9	M4x12	20	3	7,2	90	111	71	36	5,8	100	80	120	0	7	3	65	50	80	0	M5	2,5
63	2-8	130	114	63	M20	212	11	M4x12	23	4	8,5	100	123	80	40	7	115	95	140	0	10	3	75	60	90	0	M5	2,5
71	2-8	145	119	71	M20	240	14	M5X12	30	5	11,0	112	138	90	45	7	130	110	160	0	10	3,5	85	70	105	0	M6	2,5
80	2-8	175	130	80	M20	276	19	M6X16	40	6	15,5	125	157	100	50	10	165	130	200	0	12	3,5	100	80	120	0	M6	3,0
90S	2-8	195	145	90	M20	305	24	M8X19	50	8	20,0	140	173	100	56	10	165	130	200	0	12	3,5	115	95	140	0	M8	3,0
90L	2-8	195	145	90	M20	330	24	M8X19	50	8	20,0	140	173	125	56	10	165	130	200	0	12	3,5	115	95	140	0	M8	3,0
100	2-8	215	170	100	M20	371	28	M10X22	60	8	24,0	160	196	140	63	12	215	180	250	0	15	4	130	110	160	0	M8	3,5
112M	2-8	240	177	112	M25	380	28	M10X22	60	8	24,0	190	227	140	70	12	215	180	250	0	15	4	130	110	160	0	M8	3,5
132S	2-8	275	197	132	2xM32	455	38	M12X28	80	10	33,0	216	262	140	89	12	265	230	300	0	15	4	165	130	200	0	M10	3,5
132M	2-8	275	197	132	2xM32	495	38	M12X28	80	10	33,0	216	262	178	89	12	265	230	300	0	15	4	165	130	200	0	M10	3,5
160M	2-8	330	255	160	2xM40	615	42	M16X36	110	12	37,0	254	320	210	108	15	300	250	350	0	19	5	215	180	250	0	M12	4,0
160L	2-8	330	255	160	2xM40	670	42	M16X36	110	12	37,0	254	320	254	108	15	300	250	350	0	19	5	215	180	250	0	M12	4,0
180M	2-8	380	280	180	2xM40	700	48	M16X36	110	14	42,5	279	355	241	121	15	300	250	350	0	19	5						
180L	2-8	380	280	180	2xM40	740	48	M16X36	110	14	42,5	279	355	279	121	15	300	250	350	0	19	5						
200L	2-8	420	305	200	2xM50	770	55	M20X42	110	16	49,0	318	395	305	133	19	350	300	400	0	19	5						
225S	4-8	470	335	225	2xM50	815	60	M20X42	140	18	53,0	356	435	286	149	19	400	350	450	0	19	5						
225M	2	470	335	225	2xM50	820	55	M20X42	110	16	53,0	356	435	311	149	19	400	350	450	0	19	5						
225M	4-8	470	335	225	2xM50	845	60	M20X42	140	18	56,0	356	435	311	149	19	400	350	450	0	19	5						
250M	2	510	370	250	2xM63	910	60	M20X42	140	18	56,0	406	490	349	168	24	500	450	550	0	19	5						
250M	4-8	510	370	250	2xM63	910	65	M20X42	140	18	67,5	406	490	349	168	24	500	450	550	0	19	5						
280S	2	580	410	280	2xM63	985	65	M20X42	140	18	58,0	457	550	368	190	24	500	450	550	0	19	5						
280S	4-8	580	410	280	2xM63	985	75	M20X42	140	20	67,5	457	550	368	190	24	500	450	550	0	19	5						
280M	2	580	410	280	2xM63	1035	65	M20X42	140	18	58,0	457	550	419	190	24	500	450	550	0	19	5						
280M	4-8	580	410	280	2xM63	1035	75	M20X42	140	20	71,0	457	550	419	190	24	500	450	550	0	19	5						
315S	2	645	530	315	2xM63	1160	65	M20X42	140	18	58,0	508	635	406	216	28	600	550	660	0	24	6						
315S	4-8	645	530	315	2xM63	1270	80	M20X42	170	22	71,0	508	635	406	216	28	600	550	660	0	24	6						
315M	2	645	530	315	2xM63	1190	65	M20X42	140	18	58,0	508	635	457	216	28	600	550	660	0	24	6						
315M	4-8	645	530	315	2xM63	1300	80	M20X42	170	22	71,0	508	635	457	216	28	600	550	660	0	24	6						
315L	2	645	530	315	2xM63	1190	65	M20X42	140	18	58,0	508	635	508	216	28	600	550	660	0	24	6						
315L	4-8	645	530	315	2xM63	1300	80	M20X42	170	22	71,0	508	635	508	216	28	600	550	660	0	24	6						
355M	2	710	655	355	2xM63	1500	75	M20X42	140	20	67,5	610	730	500	254	28	740	680	800	0	24	6						
355M	4-8	710	655	355	2xM63	1530	95	M20X42	170	25	86,0	610	730	500	254	28	740	680	800	0	24	6						
355L	2	710	655	355	2xM63	1500	75	M20X42	140	20	67,5	610	730	630	254	28	740	680	800	0	24	6						
355L	4-8	710	655	355	2xM63	1530	95	M20X42	170	25	86,0	610	730	630	254	28	740	680	800	0	24	6						

B3

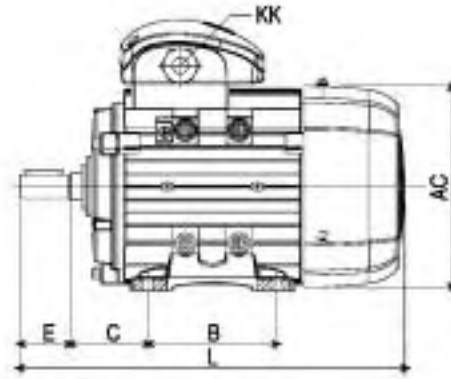
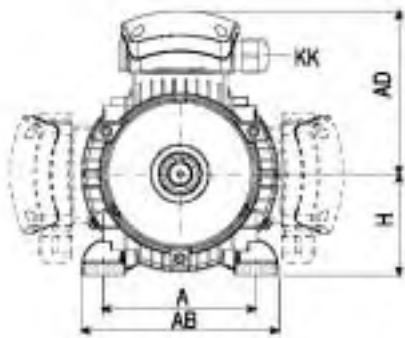

B5, B3/B5

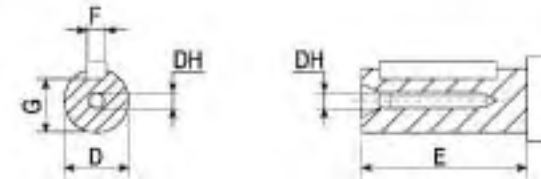
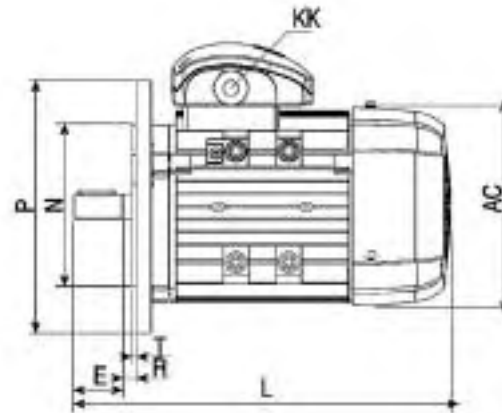
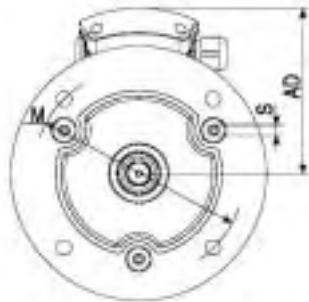

B14

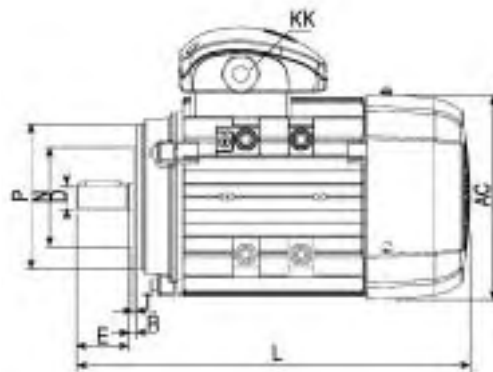
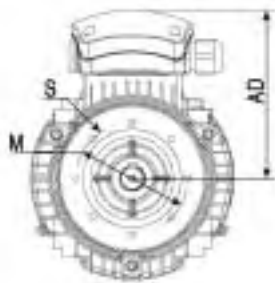

The general electrical specifications are listed in the performance charts that follow. To understand their contents, the following general definitions are provided.

Rated Power:
it is the mechanical power measured at the shaft expressed, according to the latest indications of international Standards Committees, in Watts or Kwatts. However, in the engineering sector it is still common to refer to power in terms of HP

Rated Voltage:
the voltage to be applied to the motor terminals in accordance with the specifications in the following tables

Frequency:
All electrical data in this catalogue refer to three-phase wound motors at 50 Hz. These may be connected to 60 Hz, taking into account the multiplier coefficients in the table below

rated voltage at 50Hz	Volt at 60Hz	rated power W	rpm	In	Ia / In	Ca / Cn	Cmax / Cn
230	230	1	1,2	1,2	0,8	0,8	0,8
230	240	1,1	1,2	1,15	0,9	0,9	0,9
230	260	1,2	1,2	1	1	1	1
400	400	1	1,2	1,2	0,8	0,8	0,8
400	440	1,06	1,2	1,1	0,87	0,87	0,87
400	460	1,2	1,2	1	1	1	1
400	480	1,25	1,2	1	1,1	1,1	1,1

for further information, see chapter "wiring diagrams" at page 14

Rated Current:
"In" is the Rated Current, expressed in Ampere, absorbed by the motor when supplied at rated voltage and giving the Rated Power. In the following tables, the rated currents are referred to a Voltage supply of 400V. For other voltage supplies the absorbed rated current can be considered inversely proportional to the voltage supply. EX:

Volt	230	380	400	440	690
In	1,74	1,05	1,0	0,91	0,58

Motive motors can face also temporary overloads, with Current increases of 1.5 times the rated current for at least 2 minutes.

Starting current (or locked rotor current):
In the performance charts the starting current "Is" is indicated as a multiple value of the rated current (Is/In).

Synchronous speed:
is expressed in rpm and it is obtained by the formula
 $f = 120/p$
 f= supply frequency Hz
 p= number of poles pairs

Rated torque:
Cn is expressed in Nm, and it corresponds to the rated power and rated rpm. It is given by the multiplication of the force for the arm (distance) and it is measured in Nm because the force is expressed in Newton and the distance in metres. The rated torque value is obtained by the formula

$$C_n \text{ (Nm)} = 9,55 \times (P_n/n)$$

Pn= Rated power in KW
 n= rated rotation speed in rpm

Starting torque (or locked rotor torque):
Cs is the torque that the motor can provide with the rotor at a standstill and the rated power supply.

Maximum torque:
Cmax is the maximum torque developed by the motor at the rated power supply, at a certain speed. It represents also the value of the resistant torque after which the motor stops. In the following performance charts, it is indicated the relation between maximum torque and rated torque and maximum torque (Cmax/Cn)

Power factor or cosφ:
it represents the coseno of the voltage and current gap angle.

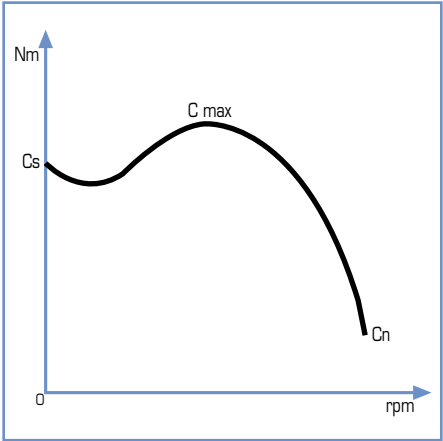

Efficiency:
η is expressed in % and it is given by the relation between the output Power and the addition of output Power and the electric losses of the motor, that is the input power absorbed by the motor. The electric motors losses are mainly of two kinds: for joule effect (rotor and stator) and iron losses. The latest cause essentially heat. An higher efficiency means energy savings, lower heating, longer life of insulating materials.



Noise:

The noise is expressed in dB(A). The measures must be taken in accordance with the standard ISO 1680-2, in order to find the Sound Power level LwA measured at 1m of distance from the perimeter of the machine.

EN 60034-9 standard describes the acoustic Power limits to be respected, indicating the maximum sound power level **LwA**. The noise values indicated in the performance charts that follow are referred to a no-load motor working, supplied at 50Hz and with a tolerance of +3 dB(A).



The moment of inertia can be calculated in this way:

$$J = (1/2) \times M \times (R^2)$$

Where M [Kg] is the rotation mass, while R [m] is the ray of the volume at cylindrical symmetry.

TOLERANCES

The data of each motor are specified in this catalogue like requested by the norm IEC 34-1. This describes, in particular, the following tolerances:

Characteristic	Tolerance
Efficiency (Output Power input Power)	-15% di (1- n)
Power factor	1/ 6 of (1- cosφ) min. 0.02 max 0.07
Locked rotor torque	-15% of the guaranteed torque +25% of the guaranteed torque
Maximum torque	-10% -of the guaranteed torque, if torque is not less than 1,5- 1,6 the rated torque
Noise	+3dB





2 Poles asynchronous speed 3000 rpm



Power KW	Power HP	Type	rpm	Current In (A)	Current Is/In	Torque Cn (Nm)	Torque Cs/Cn	Torque Cmax/Cn	Efficiency η		Pwr. Fact. $\cos\phi$		LwA (dB)	J Kgm ²	Kg
									100%	75%	100%	75%			
0,09	0,12	56A-2	2800	0,3	5,2	0,31	2,1	2,2	62,0	61,0	0,77	0,71	60	0,00010	3,5
0,13	0,18	56B-2	2800	0,3	5,2	0,41	2,1	2,2	64,0	63,5	0,78	0,73	60	0,00020	3,6
0,18	0,25	63A-2	2800	0,5	5,5	0,61	2,2	2,3	66,0	64,0	0,80	0,73	61	0,00031	4,5
0,25	0,35	63B-2	2800	0,6	5,5	0,96	2,2	2,3	69,0	68,5	0,81	0,74	61	0,00040	4,7
0,37	0,5	71A-2	2800	0,9	6,1	1,26	2,2	2,3	71,0	71,0	0,81	0,75	64	0,00055	6
0,55	0,75	71B-2	2800	1,3	6,1	1,88	2,2	2,3	74,0	73,0	0,82	0,76	64	0,00060	6,3
0,75	1	80A-2	2825	1,7	6,1	2,54	2,2	2,3	76,2	75,7	0,83	0,78	67	0,00075	10
1,1	1,5	80B-2	2825	2,4	7,0	3,72	2,2	2,3	79,3	80,0	0,84	0,82	67	0,00090	11
1,5	2	90S-2	2840	3,2	7,0	0,21	2,2	2,3	80,4	80,2	0,84	0,80	72	0,00120	13
2,2	3	90L-2	2840	4,6	7,0	7,40	2,2	2,3	81,6	82,7	0,85	0,84	72	0,00140	14
3	4	100L-2	2880	5,9	7,5	9,95	2,2	2,3	83,5	83,4	0,88	0,85	76	0,00290	25
4	5,5	112M-2	2890	7,7	7,5	13,22	2,2	2,3	85,5	85,5	0,88	0,85	77	0,00550	28
5,5	7,5	132SA-2	2900	10,3	7,5	18,11	2,2	2,3	86,5	84,5	0,89	0,88	80	0,01090	40
7,5	10	132SB-2	2900	14,0	7,5	24,70	2,2	2,3	87,1	86,9	0,89	0,89	80	0,01260	45
9,2	12,5	132MA-2	2930	16,9	7,5	25,60	2,2	2,3	87,1	86,9	0,89	0,88	81	0,02000	49
11	15	160MA-2	2930	19,9	7,5	35,85	2,2	2,3	88,4	87,4	0,89	0,87	86	0,03770	110
15	20	160MB-2	2930	26,9	7,5	48,89	2,2	2,3	89,4	88,5	0,89	0,88	86	0,04990	120
18,5	25	160L-2	2930	32,4	7,5	60,30	2,2	2,3	90,5	90,2	0,91	0,90	86	0,05500	135
22	30	180M-2	2940	41,0	7,5	71,46	2,0	2,3	90,5	89,9	0,89	0,89	89	0,07500	165
30	40	200LA-2	2950	55,5	7,5	97,12	2,0	2,3	91,4	90,3	0,85	0,83	92	0,12400	217
37	50	200LB-2	2950	67,9	7,5	119,78	2,0	2,3	92,0	91,2	0,89	0,87	92	0,13900	243
45	60	225M-2	2970	82,3	7,5	144,70	2,0	2,3	92,5	90,9	0,89	0,88	92	0,23300	320
55	75	250M-2	2970	100,4	7,5	176,85	2,0	2,3	93,0	91,9	0,86	0,84	93	0,31200	390
75	100	280S-2	2970	134,4	7,5	241,16	2,0	2,3	93,6	93,1	0,90	0,88	94	0,57900	540
90	125	280M-2	2970	160,2	7,5	289,39	2,0	2,3	94,1	93,1	0,90	0,87	94	0,67500	590
110	150	315S-2	2980	195,4	7,1	352,51	1,8	2,2	94,4	93,9	0,90	0,87	96	1,18000	880
132	180	315MA-2	2980	233,2	7,1	423,02	1,8	2,2	94,8	94,3	0,88	0,85	96	1,82000	1000
160	215	315LA-2	2980	265,0	7,1	512,75	1,8	2,2	95,0	94,5	0,91	0,88	99	2,08000	1055
200	270	315LB-2	2980	330,0	7,1	640,94	1,8	2,2	95,0	94,5	0,90	0,88	99	2,38000	1110
250	335	355M-2	2985	411,0	7,1	799,83	1,8	2,2	95,0	94,0	0,90	0,88	103	3,00000	1900
315	423	355L-2	2985	517,0	7,1	100,79	1,8	2,2	95,2	95,2	0,91	0,89	103	3,50000	2300



4 Poles asynchronous speed 1500 rpm



Power KW	Power HP	Type	rpm	Current In (A)	Current Is/In	Torque Cn (Nm)	Torque Cs/Cn	Torque Cmax/Cn	Efficiency η		Pwr. Fact. $\cos\phi$		LwA (dB)	J Kgm ²	Kg
									100%	75%	100%	75%			
0,06	0,09	56A-4	1340	0,20	4,0	0,43	2,0	2,1	56,0	55,6	0,69	0,61	52	0,00015	3,5
0,09	0,12	56B-4	1340	0,30	4,0	0,64	2,0	2,1	58,0	58,2	0,7	0,61	52	0,00015	3,6
0,13	0,18	63A-4	1360	0,40	4,4	0,84	2,1	2,2	59,0	59,0	0,72	0,63	52	0,00030	4,5
0,18	0,25	63B-4	1360	0,60	4,4	1,26	2,1	2,2	62,0	61,5	0,73	0,65	52	0,00040	4,7
0,25	0,35	63C-4	1330	0,73	4,9	1,51	2,1	2,2	64,3	64,0	0,74	0,66	55	0,00045	5,7
0,25	0,35	71A-4	1380	0,80	5,2	1,73	2,1	2,2	68,0	66,5	0,74	0,65	55	0,00050	6
0,37	0,5	71B-4	1380	1,06	5,2	2,54	2,1	2,2	69,3	71,0	0,76	0,65	55	0,00080	6,3
0,55	0,75	71C-4	1340	1,44	5,2	3,12	2,3	2,3	72,0	71,5	0,75	0,66	58	0,00150	7,3
0,55	0,75	80A-4	1400	1,49	5,2	3,78	2,3	2,3	72,8	72,6	0,75	0,66	58	0,00180	10
0,75	1	80B-4	1400	1,93	6,0	5,15	2,3	2,3	74,4	74,2	0,74	0,65	58	0,00210	11
1,1	1,5	80C-4	1390	2,67	6,0	7,10	2,3	2,3	76,2	76,0	0,77	0,7	61	0,00220	12,5
1,1	1,5	90S-4	1400	2,75	6,0	7,50	2,3	2,3	76,4	77,8	0,79	0,7	61	0,00230	13
1,5	2	90L-4	1400	3,52	6,0	10,23	2,3	2,3	78,5	78,1	0,81	0,75	61	0,00270	14
2,2	3	90LB-4	1390	4,86	7,0	13,20	2,3	2,3	81,5	81,0	0,79	0,71	64	0,00410	16
2,2	3	100LA-4	1420	4,90	7,0	14,80	2,3	2,3	82,5	83,0	0,82	0,76	64	0,00540	23
3	4	100LB-4	1420	6,44	7,0	20,18	2,3	2,3	82,6	83,2	0,86	0,78	64	0,00670	25
4	5,5	112M-4	1440	8,36	7,0	26,53	2,3	2,3	85,0	84,8	0,83	0,76	65	0,00950	28
5,5	7,5	112MB-4	1440	11,20	7,0	32,30	2,3	2,3	85,9	85,1	0,83	0,79	71	0,01500	35
5,5	7,5	132S-4	1440	11,20	7,0	36,48	2,3	2,3	86,7	86,8	0,87	0,81	71	0,02140	45
7,5	10	132MA-4	1460	14,80	7,0	49,74	2,3	2,3	87,9	88,2	0,87	0,83	71	0,02960	55
9,2	12,5	132MB-4	1460	17,90	7,0	60,05	2,3	2,3	87,9	88,2	0,85	0,83	72	0,03100	59
11	15	160M-4	1460	21,10	7,0	71,59	2,3	2,3	89,2	89,2	0,85	0,83	75	0,07470	118
15	20	160L-4	1460	28,60	7,5	98,12	2,3	2,3	89,7	89,7	0,85	0,82	75	0,09180	132
18,5	25	180M-4	1470	34,60	7,5	120,19	2,2	2,3	90,7	90,6	0,89	0,86	76	0,13900	164
22	30	180L-4	1470	41,00	7,5	142,93	2,2	2,3	91,6	91,7	0,88	0,85	76	0,15800	182
30	40	200L-4	1480	54,70	7,2	160,96	2,2	2,3	92,6	92,4	0,87	0,84	79	0,26200	245
37	50	225S-4	1480	66,40	7,2	198,51	2,2	2,3	92,8	92,7	0,87	0,84	81	0,40600	258
45	60	225M-4	1480	80,40	7,2	290,37	2,2	2,3	93,4	93,3	0,89	0,87	81	0,46900	290
55	75	250M-4	1480	97,80	7,2	354,90	2,2	2,3	94,0	94,2	0,89	0,88	83	0,66000	388
75	100	280S-4	1480	133,00	7,2	483,95	2,2	2,3	94,0	93,5	0,91	0,89	86	1,12000	510
90	120	280M-4	1485	158,70	7,2	578,79	2,2	2,3	94,0	93,5	0,88	0,86	86	1,46000	606
110	150	315S-4	1485	191,00	6,9	707,41	2,1	2,2	94,0	93,5	0,88	0,87	93	3,11000	910
132	180	315M-4	1485	228,00	6,9	848,89	2,1	2,2	94,8	94,8	0,91	0,88	93	3,62000	1000
160	220	315LA-4	1485	273,00	6,9	1028,96	2,1	2,2	95,0	94,5	0,88	0,85	97	4,13000	1055
200	270	315LB-4	1485	341,00	6,9	1286,20	2,1	2,2	95,0	94,1	0,89	0,87	97	4,73000	1128
250	335	355M-4	1485	421,00	6,9	1602,35	2,1	2,2	95,0	94,4	0,89	0,87	101	6,50000	1700
315	423	355L-4	1485	528,00	6,9	2018,96	2,1	2,2	95,0	95,0	0,89	0,86	101	8,20000	1900



6 Poles asynchronous speed 1000 rpm



Power KW	Power HP	Type	rpm	Current In (A)	Current Is/In	Torque Cn (Nm)	Torque Cs/Cn	Torque Cmax/Cn	Efficiency η		Pwr. Fact. $\cos\phi$		LwA (dB)	J Kgm ²	Kg
									100%	75%	100%	75%			
0,18	0,25	71A-6	900	0,70	4,0	1,91	1,9	2,0	57,0	57,0	0,66	0,60	52	0,00110	6
0,25	0,35	71B-6	900	0,90	4,0	2,65	1,9	2,0	60,0	59,9	0,68	0,60	52	0,00140	6,3
0,37	0,5	80A-6	900	1,20	4,7	3,93	1,9	2,0	66,5	67,7	0,70	0,62	54	0,00160	10
0,55	0,75	80B-6	900	1,70	4,7	5,84	1,9	2,1	68,2	68,4	0,66	0,59	54	0,00190	11
0,75	1	90S-6	910	2,10	5,5	7,87	2,0	2,1	74,4	73,9	0,74	0,64	57	0,00290	13
1,1	1,5	90L-6	910	3,0	5,5	11,54	2,0	2,1	75,2	74,7	0,75	0,66	57	0,00350	14
1,5	2	100L-6	940	3,70	5,5	15,24	2,0	2,1	77,6	77,6	0,73	0,66	61	0,00690	23
2,2	3	112M-6	940	5,20	6,5	22,35	2,1	2,1	79,9	79,9	0,75	0,66	65	0,01400	25
3	4	132S-6	960	6,80	6,5	29,84	2,1	2,1	84,5	84,6	0,77	0,71	69	0,02860	28
4	5,5	132MA-6	960	9,0	6,5	39,79	2,1	2,1	84,6	84,7	0,77	0,70	69	0,03570	45
5,5	7,5	132MB-6	960	11,90	6,5	54,71	2,1	2,1	85,7	86,0	0,81	0,76	69	0,04490	55
7,5	10	160M-6	970	16,0	6,5	73,84	2,1	2,1	87,0	87,0	0,76	0,71	73	0,00810	78
11	15	160L-6	970	22,50	6,5	108,30	2,1	2,1	89,0	89,5	0,78	0,73	73	0,11600	90
15	20	180L-6	970	31,60	7,0	147,68	2,1	2,1	89,1	89,1	0,84	0,79	73	0,20700	160
18,5	25	200LA-6	970	38,60	7,0	182,14	2,1	2,1	90,0	90,2	0,82	0,78	76	0,31500	217
22	30	200LB-6	970	44,70	7,0	216,60	2,1	2,1	90,1	90,1	0,83	0,78	76	0,36000	244
30	40	225M-6	980	59,30	7,0	292,35	2,0	2,1	91,8	91,5	0,88	0,79	76	0,54700	295
37	50	250M-6	980	71,10	7,0	360,56	2,1	2,1	92,8	92,8	0,86	0,86	78	0,84300	365
45	60	280S-6	980	85,90	7,0	438,52	2,1	2,1	93,0	92,5	0,87	0,83	80	1,39000	500
55	75	280M-6	980	104,70	7,0	535,97	2,1	2,1	93,0	92,5	0,88	0,85	80	1,65000	545
75	100	315S-6	980	141,70	7,0	730,87	2,0	2,0	94,0	93,5	0,88	0,85	85	4,11000	810
90	125	315MA-6	985	169,50	6,7	872,59	2,0	2,0	94,0	93,5	0,86	0,85	85	4,78000	900
110	150	315LA-6	985	206,70	6,7	1066,50	2,0	2,0	94,3	93,9	0,86	0,84	85	5,45000	1010
132	180	315LB-6	985	244,70	6,7	1279,80	2,0	2,0	94,7	94,2	0,87	0,84	85	6,12000	1140
160	220	355MA-6	990	277,00	6,7	1543,43	1,9	2,0	94,9	94,2	0,87	0,87	92	9,50000	1550
200	270	355MB-6	990	347,00	6,7	1292,29	1,9	2,0	94,9	94,5	0,89	0,87	92	10,40000	1600
250	335	355L-6	990	432,00	6,7	2411,62	1,9	2,0	95,0	95,0	0,88	0,86	92	12,40000	1700



8 Poles asynchronous speed 750 rpm



Power KW	Power HP	Type	rpm	Current In (A)	Current Is/In	Torque Cn (Nm)	Torque Cs/Cn	Torque Cmax/Cn	Efficiency η		Pwr. Fact. $\cos\phi$		LwA (dB)	J Kgm ²	Kg
									100%	75%	100%	75%			
1,5	2	112M-8	700	4,28	5,0	20,46	1,8	2,0	77,2	77,3	0,69	0,60	61	0,02450	28
2,2	3	132S-8	710	5,70	6,0	29,59	1,8	2,0	81,9	82,2	0,72	0,66	64	0,03140	45
3	4	132M-8	710	7,53	6,0	40,35	1,8	2,0	83,0	83,4	0,74	0,67	64	0,03950	55
4	5,5	160MA-8	720	9,80	6,0	53,06	1,9	2,0	86,0	85,8	0,74	0,64	68	0,07530	105
5,5	7,5	160MB-8	720	12,60	6,0	72,59	2,0	2,0	86,6	87,3	0,77	0,71	68	0,09310	78
7,5	10	160L-8	720	16,90	6,0	99,50	2,0	2,0	87,2	88,1	0,79	0,74	68	0,12600	90
11	15	180L-8	730	23,80	5,5	143,90	2,0	2,0	87,8	87,9	0,77	0,70	70	0,20300	160
15	20	200L-8	730	32,40	6,6	196,23	2,0	2,0	88,2	88,7	0,77	0,70	73	0,33900	235
18,5	25	225S	730	39,00	6,6	242,02	1,9	2,0	91,3	91,5	0,76	0,72	73	0,49100	242
22	30	225M-8	730	45,00	6,6	287,81	1,9	2,0	90,0	90,7	0,78	0,75	73	0,54700	285
30	40	250M-8	730	60,80	6,6	392,47	1,9	2,0	92,4	92,3	0,81	0,76	75	0,84300	390
37	50	280S-8	730	74,00	6,6	484,04	1,9	2,0	92,5	92,4	0,78	0,73	76	1,93000	500
45	60	280M-8	740	89,30	6,6	580,74	1,8	2,0	92,6	92,6	0,78	0,73	76	1,65000	580
55	75	315S-8	740	105,00	6,6	709,80	1,8	2,0	93,0	93,0	0,82	0,76	82	4,79000	790
75	100	315MA-8	740	143,00	6,6	967,91	1,8	2,0	93,5	93,5	0,82	0,78	82	5,58000	970
90	125	315MB-8	740	169,00	6,6	1161,49	1,8	2,0	93,7	93,5	0,82	0,78	82	6,37000	1055
110	150	315MC-8	740	206,00	6,4	1419,60	1,8	2,0	94,1	94,5	0,83	0,80	82	7,23000	1118

COMPONENTS LIST

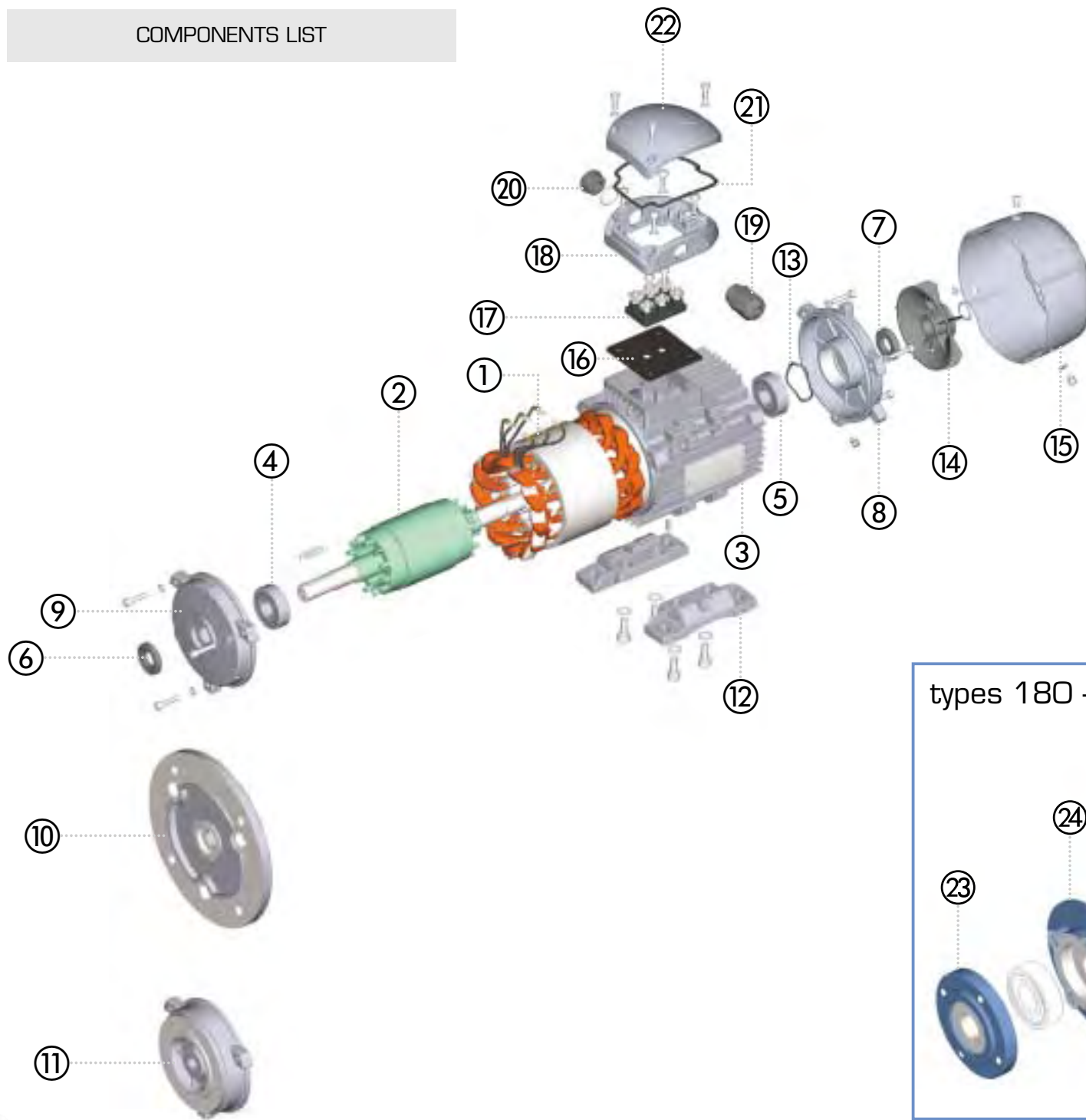

N°	CODE
1	3PNSTA
2	3PNROT
3	3PNFRA
4	3PNFBE
5	3PNBBE
6	3PNFOS
7	3PNBOS
8	3PNBSH
9	3PNBO3
10	3PNBO5
11	3PNB14
12	3PNFEE
13	3PNWAV

N°	CODE
14	3PNFAN
15	3PNFCV
16	3PNUCB
17	3PNTER
18	3PNBCB
19	3PNCMP
20	3PNCAP
21	3PNSCB
22	3PNCCB
23	3PNFOB
24	3PNFIB
25	3PNBIB
26	3PNBOB



RUBBER SEAL RINGS AND BEARINGS

FRAME SIZE	POLES NUMBER	RUBBER SEAL RING		BEARINGS	
		⑥	⑦	④	⑤
56-63	2 - 8	12x25x7	12x25x7	6201	6201
71	2 - 8	15x30x7	15x30x7	6202	6202
80	2 - 8	20x35x7	20x35x7	6204	6204
90	2 - 8	25x40x7	25x40x7	6205	6205
100	2 - 8	30x47x7	30x47x7	6206	6206
112	2 - 8	30x47x7	30x47x7	6206	6206
132	2 - 8	40x62x7	40x62x7	6208	6208
160	2	45x62x12	45x62x12	6209	6209
160	4 - 8	45x62x12	45x62x12	6309	6309
180	2	55x75x12	55x75x12	6211	6211
180	4 - 8	55x75x12	55x75x12	6311	6211
200	2	60x80x12	60x80x12	6212	6212
200	4 - 8	60x80x12	60x80x12	6312	6212
225	2	65x90x12	65x90x12	6312	6312
225	4 - 8	65x90x12	65x90x12	6313	6312
250	2	70x90x12	70x90x12	6313	6313
250	4 - 8	70x90x12	70x90x12	6314	6313
280	2	80x110x12	80x110x12	6314	6314
280	4 - 8	80x110x12	80x110x12	6317	6314
315	2	95x120x12	95x120x12	6316	6316
315	4 - 8	95x120x12	95x120x12	NU 319	6319
355	2	95x120x12	95x120x12	NU 319	6319
355	4 8	95x120x12	95x12x12	NU 322	NU 322

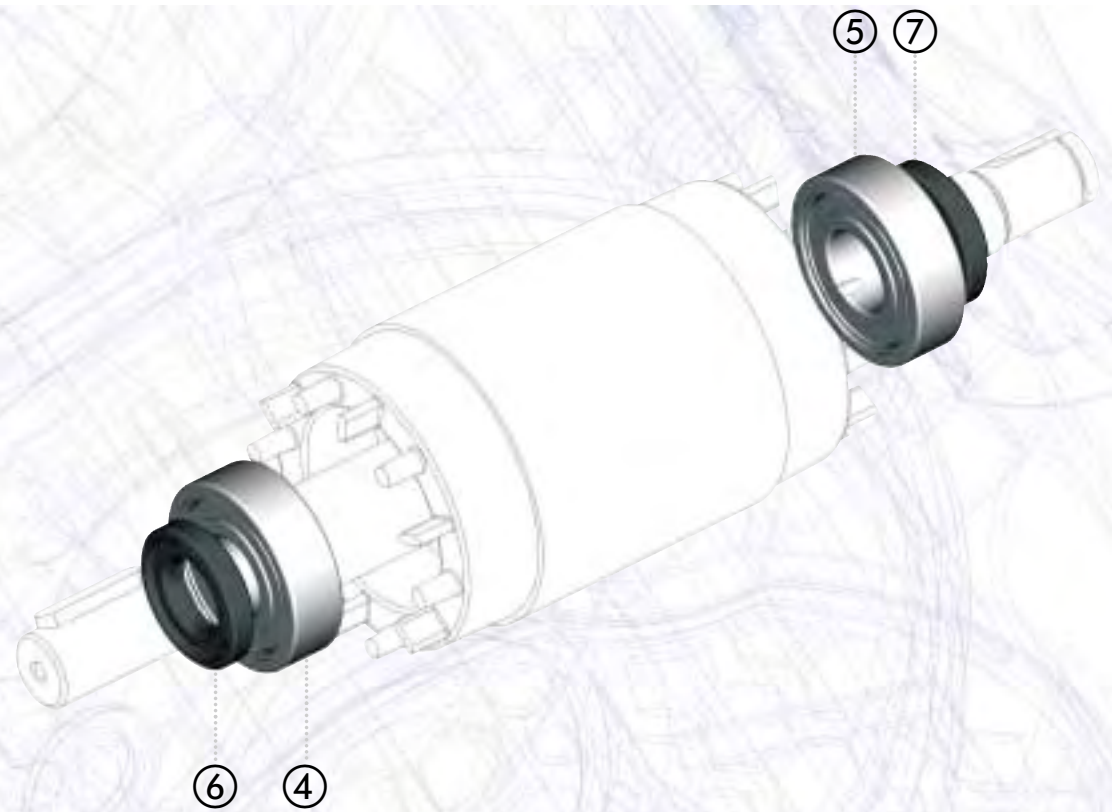

2 bearings lubrication devices on the front and the back shield are provided in motors from size 180 and up. Other motors mount staunch bearings pre-lubricated for life

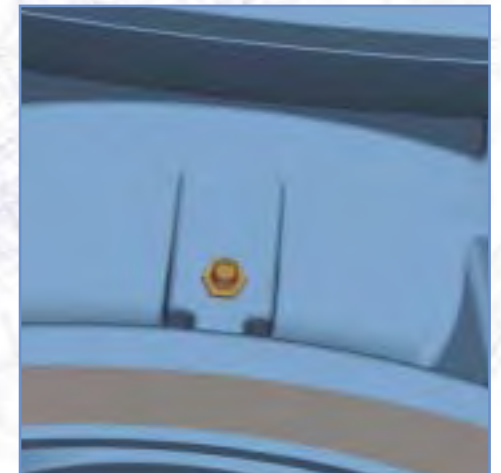





TERMS OF SALE AND GUARANTEE

ARTICLE 1 GARANTEE

1.1. Barring written agreements, entered into between the parties hereto each time, Motive hereby guarantees compliance of products supplied and compliance with specific agreements.

The guarantee for defects shall be restricted to product defects following design, materials or manufacturing defects leading back to Motive.

The Guarantee shall not include:

-  faults or damages ensuing from transport., faults or damages ensuing from installation defects; incompetent use of the product, or any other unsuitable use.
-  tampering or damages ensuing from use by non-authorized staff and/or use of non-original parts and/or spare parts;
-  Defects and/or damages ensuing from chemical agents and/or atmospheric phenomena (e.g. burnt out material, etc.); routine maintenance and required action or checks;
-  Products lacking a plate or having a tampered plate.

1.2. Returns to credit or replace will be accepted only in exceptional cases; However returns of goods already used to credit or replace won't be accepted in any case.

The guarantee shall be effective for all Motive products, with a term of validity of 12 months, starting from the date of shipment.

The guarantee shall be subject to specific written request for Motive to take action, according to statements, as described at the paragraphs hereinbelow. By virtue of aforesaid approval, and as regards the claim, Motive shall be bound, at its discretion, and within a reasonable time-limit, to alternatively take the following action:

- a) To supply the Buyer with products of the same type and quality as those having proven defective and not complying with agreements, free ex-works; in aforesaid case, Motive shall have the right to request, at the Buyer's charge, early return of defective goods, which shall become Motive's property;
- b) To repair, at its charge, the defective product or to modify the product which does not comply with agreements, by performing aforesaid action at its facilities; in aforesaid cases, all costs regarding product transport shall be sustained by the Buyer.
- c) To send spare parts free of charge: all costs regarding product transport shall be sustained by the Buyer.

1.3 The guarantee herein shall assimilate and replace legal guarantees for defects and discrepancies, and shall exclude any other eventual Motive liability, however caused by supplied products; in particular, the Buyer shall have no right to submit any further claims.

Motive shall not be liable for the enforcement of any further claims, as of the date the guarantee's term of validity expires.

ARTICLE 2 CLAIMS

2.1. Without prejudice to the application of provisions in Law, dated June 21, 1971, and as per Article 1: Claims, regarding quantity, weight, gross weight and colour, or claims regarding faults and defects in quality or compliance, and which the Buyer may discover on goods delivery, shall be submitted by a max. 7 days of aforesaid discovery, under penalty of nullity.

ARTICLE 3 DELIVERY

3.1. Any liability for damages ensuing from total or partial delayed or failed delivery, shall be excluded.

3.2. Unless differently communicated by written to the Client, the transport terms have to be intended ex-works

ARTICLE 4 PAYMENT

4.1. Any delayed or irregular payments shall entitle Motive to cancel ongoing agreements, including agreements which do not regard the payments at issue, as well as entitling Motive to claim damages, if any. Motive shall, however, have the right, as of the payment's due date and without placing in arrears, to claim interest for arrears, to the extent of the discount rate in force in Italy, increased by 5 points. Motive shall also have the right to withhold material under repair for replacement. In the case of failed payment, Motive shall have the right to cancel all guarantees on materials, as regards the insolvent Client.

4.2. The Buyer shall be bound to complete payment, including cases whereby claims or disputes are underway.

ALL DATA HAVE BEEN WRITTEN AND CHECKED WITH THE GREATEST CARE. WE DO NOT TAKE ANY RESPONSIBILITY FOR POSSIBLE ERRORS OR OMISSIONS. MOTIVE CAN CHANGE THE CHARACTERISTICS OF THE SOLD ITEMS ON HIS FIRM OPINION AND IN EVERY MOMENT.



Motive s.r.l.

Via G. D'Annunzio, 11 - 25018 MONTICHIARI (BS) - Italy

Tel. +39.030.9962342 - Fax +39.030.962011

web site: www.motive.it - e-mail: motive@e-motive.it

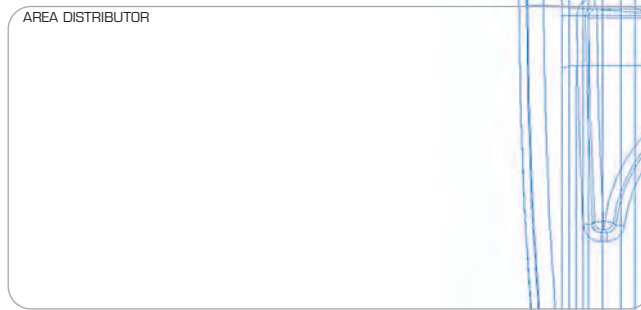

AREA DISTRIBUTOR